

MAL

High Power, High Temperature heating cable for use on pipework and vessels.

MI CABLE

**Alloy 825 Sheathed
Mineral Insulated Heating Cable**

- High performance output
- Wide temperature range
- 300V & 600V twin core, and 600V single core versions
- Fire resistant
- High mechanical resistance
- Corrosion resistant

INTRODUCTION

The MAL range of Alloy 825 sheathed Mineral Insulated (MI) heating cable has been developed to meet the specific need for a cable having a high temperature capability and electrical resistance values needed for long circuit lengths.

To meet the requirement, Heat Trace have combined an Alloy 825 with heating conductors to enable an operating temperature of 600°C with resistance values from 36100Ω/km down to 5.3Ω/km.

MI Cables have excellent mechanical strength and are non-combustible. They are series resistance heaters which must be designed to provide the required heat output.

APPLICATIONS

The high temperature capabilities may be required for the following typical applications:-

Nuclear Industry - Sodium loops

Building Industry - Bitumen / asphalt heating

Metal Forming Industry - Melting of low melt alloys

The ability to be easily formed into shapes is useful for tank/vessel heating where unusual shapes (cones, hoppers, etc.) are encountered.

MI Cables may be used for most other general heat tracing applications if designed to provide the correct output. They may also be found in all underfloor (roads, ramps, sports grounds, horticultural, agricultural, space) heating duties where the mechanical strength of the cable is required.

MAL CORROSION RESISTANCE

SUBSTANCE	USAGE / RESISTANCE
Sulphuric Acid	Suitable under most conditions
Hydrochloric Acid	Acceptable
Hydrofluoric Acid	Suitable under most conditions
Phosphoric Acid	Suitable under most conditions
Nitric Acid	Suitable under most conditions
Organic Acid	Suitable under most conditions
Acetic Acid	Suitable under most conditions
Sea Water	Suitable under most conditions
Chloride Dry	Suitable under most conditions

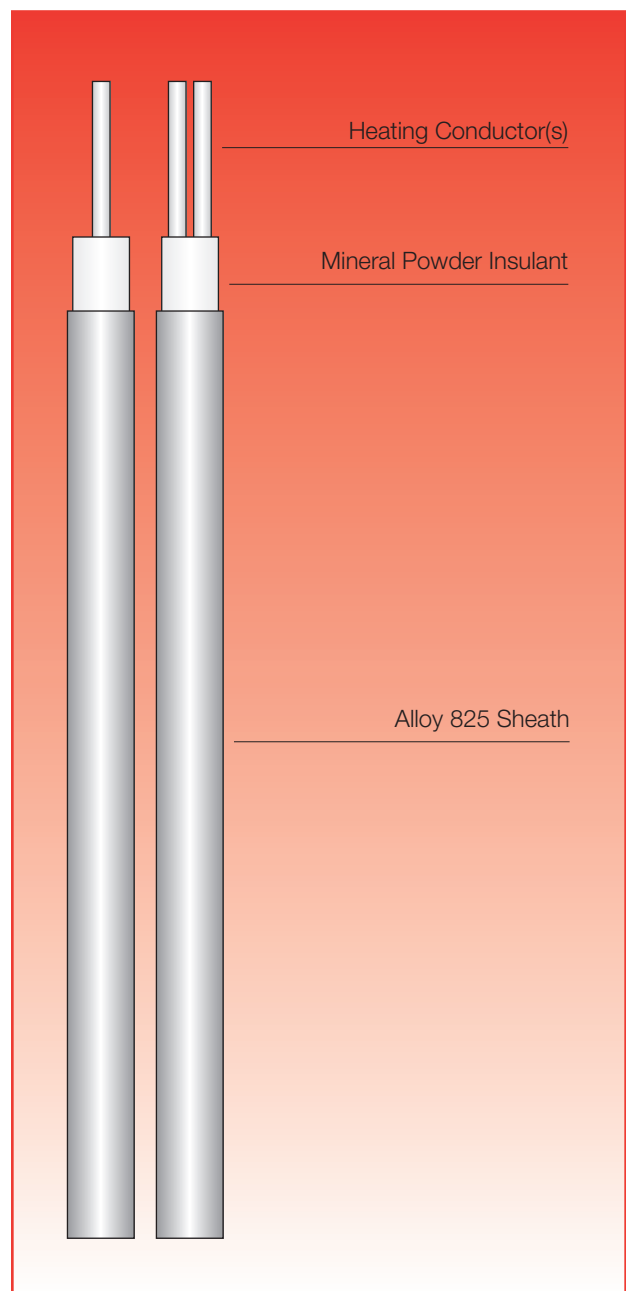

SPECIFICATION

SINGLE CORE, 600V MAXIMUM OPERATING VOLTAGE

CABLE REF	CABLE DIA (mm)	CABLE RES @ 20°C Ω/m	COLD LEAD-IN CABLE		RATING FACTOR
			SIZE mm ²	DIA (mm)	
MAL4.301N6560	4.3	6.56	2.14	5.3	1.0
MAL4.301N5250	4.3	5.25	2.14	5.3	1.0
MAL4.301N4260	4.3	4.26	2.14	5.3	1.0
MAL4.301B3280	4.3	3.28	2.14	5.3	1.0
MAL4.301B2790	4.3	2.79	2.14	5.3	1.0
MAL4.301B2300	4.3	2.30	2.14	5.3	1.0
MAL4.301B1640	4.3	1.64	2.14	5.3	1.0
MAL4.301B1250	4.3	1.25	2.14	5.3	1.0
MAL4.301B0980	4.3	0.98	2.14	5.3	1.0
MAL4.301B0820	4.3	0.82	2.14	5.3	1.0
MAL4.401B0660	4.4	0.66	2.14	5.3	0.98
MAL4.601B0560	4.6	0.56	2.14	5.3	0.94
MAL4.301A0490	4.3	0.49	2.14	5.3	1.0
MAL4.301A0330	4.3	0.33	5.5	6.81	1.0
MAL4.301A0260	4.3	0.26	5.5	6.81	1.0
MAL4.301A0230	4.3	0.23	5.5	6.81	1.0
MAL4.301A0200	4.3	0.2	5.5	6.81	1.0
MAL4.571A0130	4.57	0.13	5.5	6.81	0.95
MAL4.701A0100	4.7	0.1	5.5	6.81	0.92
MAL5.081A0066	5.08	0.066	5.5	6.81	0.85
MAL4.341CU0034	4.34	0.034	5.5	6.81	1.0
MAL4.601CU0021	4.6	0.021	5.5	6.81	0.94
MAL5.001CU0013	5.0	0.013	5.5	6.81	0.86
MAL5.301CU0008	5.3	0.0085	5.5	6.81	0.82
MAL6.101CU0005	6.1	0.0053	8.43	7.62	0.71

TWIN CORE, 600V MAXIMUM OPERATING VOLTAGE

MAL5.502N36100	5.5	36.1	2.0	7.37	0.79
MAL5.802N29500	5.8	29.5	2.0	7.37	0.75
MAL5.802N19700	5.8	19.7	2.0	7.37	0.75
MAL6.002N13100	6.0	13.1	2.0	7.37	0.72
MAL6.902N06560	6.9	6.56	2.0	7.37	0.63
MAL6.502B03280	6.5	3.28	2.0	7.37	0.66
MAL6.502B02300	6.5	2.3	2.0	7.37	0.66
MAL6.502B01640	6.5	1.64	2.0	7.37	0.66
MAL6.502B00980	6.5	0.98	3.33	9.27	0.66
MAL6.502A00660	6.5	0.66	3.33	9.27	0.66
MAL6.702A00490	6.7	0.49	3.33	9.27	0.64
MAL7.102A00330	7.1	0.33	3.33	9.27	0.61
MAL7.502A00230	7.5	0.23	3.33	9.27	0.58

CABLE SHEATH

Alloy 825

CABLE INSULATION

MgO

INSULATION RESISTANCE

1000 M Ω /1000m

MAXIMUM SHEATH TEMPERATURE

600°C (1112°F)

EARTH LEAKAGE

3mA/100m

ORDERING CODE

MAL 7.5 2 A 00230

Alloy 825 Sheath
 Diameter of Cable (mm)
 Number of Conductors
 Conductor Material:-
 (CU=Copper, A=Alloy 60,
 B=Constantan, N=Nichrome)
 Conductor Resistance †

† Conductor resistance is measured in Ohms per 1000m

TWIN CORE, 300V MAXIMUM OPERATING VOLTAGE

CABLE REF	CABLE DIA (mm)	CABLE RES @ 20°C Ω/m	COLD LEAD-IN CABLE		RATING FACTOR
			SIZE mm ²	DIA (mm)	
MAL4.102N36100	4.1	36.1	2.0	7.37	1.05
MAL4.102N29500	4.1	29.5	2.0	7.37	1.05
MAL4.102N24600	4.1	24.6	2.0	7.37	1.05
MAL4.102N19700	4.1	19.7	2.0	7.37	1.05
MAL4.102N16400	4.1	16.4	2.0	7.37	1.05
MAL4.102N13100	4.1	13.1	2.0	7.37	1.05
MAL4.102N10500	4.1	10.5	2.0	7.37	1.05
MAL4.102B09000	4.1	9.0	2.0	7.37	1.05
MAL4.102B08200	4.1	8.2	2.0	7.37	1.05
MAL4.102B06600	4.1	6.6	2.0	7.37	1.05
MAL4.102B05600	4.1	5.6	2.0	7.37	1.05
MAL4.102B04600	4.1	4.6	2.0	7.37	1.05
MAL4.322B03300	4.32	3.3	2.0	7.37	1.0
MAL4.572B02300	4.57	2.3	2.0	7.37	0.95
MAL4.952B01600	4.95	1.6	2.0	7.37	0.87
MAL4.322A00980	4.32	0.98	3.33	9.27	1.0
MAL4.322A00820	4.32	0.82	3.33	9.27	1.0
MAL4.322A00660	4.32	0.66	3.33	9.27	1.0
MAL4.452A00490	4.45	0.49	3.33	9.27	0.97
MAL4.952A00330	4.95	0.33	3.33	9.27	0.87
MAL5.332A00230	5.33	0.23	3.33	9.27	0.81
MAL5.842A00160	5.84	0.16	3.33	9.27	0.74

RATING FACTOR

Use the graph below to ensure that the cable sheath does not operate at an unsafe temperature.

1. Determine the "corrected" cable power output by multiplying actual design output by the rating factor in the table opposite.
2. Find the point on the graph where the "corrected" W/m output intersects with the maintain temperature of the equipment to be heated (interpolation may be necessary).
3. Read off from the left hand (y) axis the anticipated cable sheath temperature. This must be less than the cable maximum withstand temperature, and below any other limiting temperatures, eg. Temperature Classification.

POWER OUTPUT vs. SHEATH TEMPERATURE

Cable Sheath Temperature (°C)

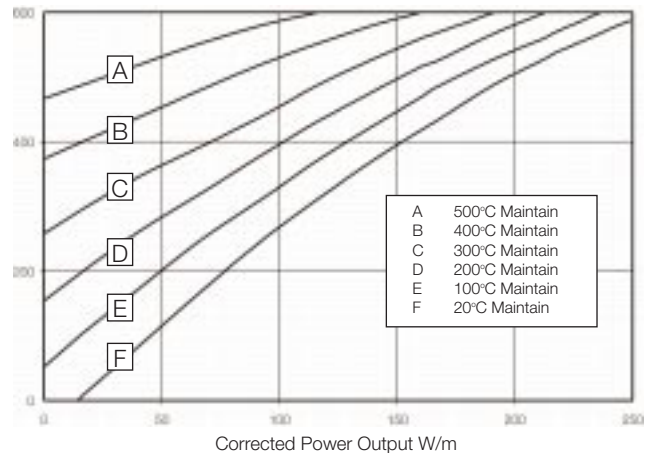

HEAT TRACE™
 SETTING THE STANDARDS LEADING THE WAY

Tracer House, Cromwell Road, Bredbury, Stockport, Cheshire, SK6 2RF, UK
 Tel: +44 (0)161-430 8333 Fax: +44 (0)161-430 8654 <http://www.heat-trace.com>

The information given herein, including drawings, illustrations and schematics (which are intended for illustration purposes only), is believed to be reliable. However, Heat Trace Ltd makes no warranties as to its accuracy or completeness and disclaims any liability in connection with its use. Users of Heat Trace Ltd products should make their own evaluation to determine the suitability of each such product for specific applications. In no way will Heat Trace Ltd be liable for any damages arising out of the misuse, resale or use of the product.